



Schwiebacher Abbruch Technik

Werkstatt • Lager • Service seit 1977

D-82229 Seefeld (bei München)

Graf-Toerring-Seefeld-Strasse 9b / 17

Tel. 08152 / 998 969-0 Fax.- 9

T.45 LADE-SCHWENK-LÖFFEL *optimal** (2 Zylinder stehend, Holland-Profil) für Bagger von 5,3 bis 7,0 to

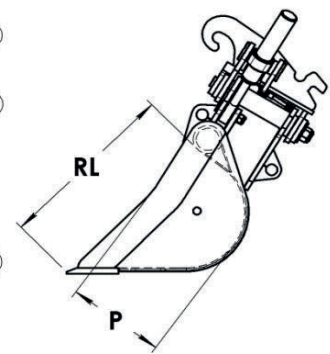
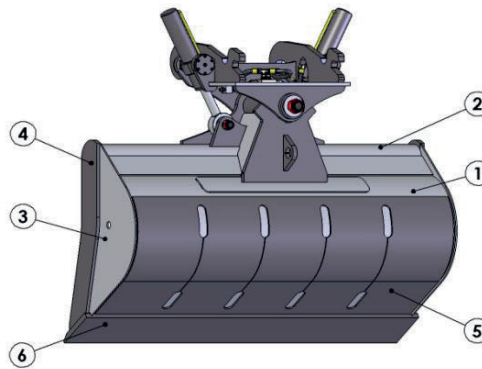
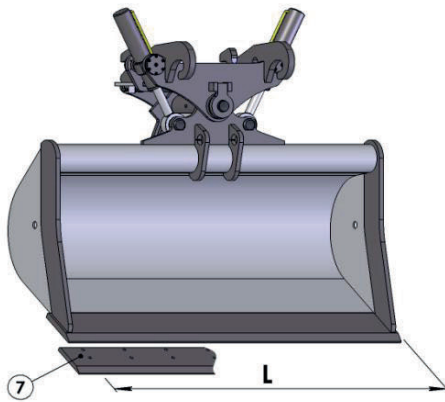
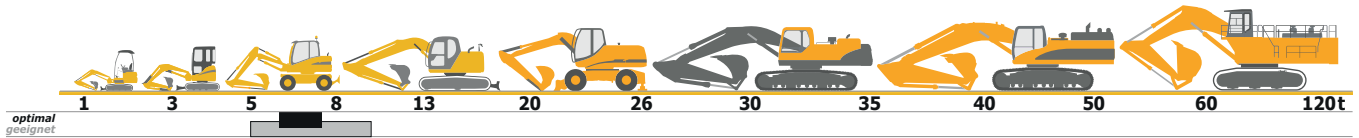

Klasse Class Classe	Bestell Nr. Code Code	L mm.	Cap. SAE Lt.	Anz. Zylinder Cylinders Vérins	Gewicht kg Weight Poids	RL mm.	P mm.	Preis Price List Tarif	Unterschraubmesser Bolt on Blade Lame boulonnées
T.45 5,3-7,0 ton	T45ORO140	1400	288	2	403	588	323		
	T45ORO150	1500	310	2	417				
	T45ORO160	1600	334	2	430				
		1	2	3	4	5	6	/	7 Optional
Material	Material Matériel	Fe 510	Fe 510	Fe 510	Hardox	Fe 510	Hb 400	/	Hb 400
Materialstärke	Thickness Espessure	6 mm	114.3 x 12.5 mm	5 mm	15 mm	6 mm	200 x 20 mm	/	200 x 20 mm

*optimal = für Bagger von 5,3 bis 7,0 t mit Standard-Ausrüstung.

Benati G 41/G 47/G 49/G 53/2.19; **Benfra** 1.35/1.35B/1.45/6531/8531/BF35 00/E6/E7/E8/E 206; **Case** 580/580E/580F/580G/580K/580SLE/580XLT/590SLE/595SLE/695SM; **Caterpillar** 321/322/428B/428C/43 8C/436C/438D/446B; **Cimas** 930/950/970; **Eurocomach** ES 6500; **Euromach** 6000/6500; **Fai** 100DT/45B/D/E/46C/D/E/575/585/590/595/96DT/890/892/894/898; **Fermec** 860/960; **Fiat Hitachi** FB 7B/FB 90/90.2/FB 100/100.2/FB 110/110.2/FB 200.2/FB 4004WS/FT 700/FR 800; **Ford** 550/555/555C/655C/665/675/675DT/875/NH95; **Foredil** 30.13/40.13; **Halla** 50HE; **Ihi-Imer** 65NX; **JCB** 3CX/4CX; **Kamo** 3X TURBO/MOBIL 60S; **Kobelco** SK 70SR; **Komatsu** PC 60.7/WB 91R/WB 91R2/WB 9 3R/WB 93R2/WB 95R/WB 97R/WB 97R2/WB 98A; **Kubota** KH 191/KX 191; **Libra** 150S/150W/250/254S; **MF** 50B/D/H/HX/HXB/HXR/HXS/60HX/HXS/750/860/865/960/965; **Macmoter** M 6 M/BW 65; **Mecalac** 8CX/10 MSX; **New Holland** E 70SR/L 90/L 95/L 110/L 115.B; **Palazzani** PB 70.2/PB 80.3/PB 90.3; **Pel Job** EB 706; **Schaeff** HR 31/HR 32/HML 30/HML 31/HML 32/SKB 800/SKB 902; **Takeuchi** TB 070/TB 070W; **Terex** HR 32; **Venieri** VF 9.23/VF 10.23B/VF 10.33/VF 8.23B/C/VF 8.33; **Volvo** BL 71/EC 70/EW 70; **Yanmar** B 70/B 7E/B 7SIGMA/Vio 70.

geeignet = für Bagger von 5,0 bis 10 t je nach Ausrüstung.
Andere Klassen/Größen bedingt geeignet. Bei Bedarf bitte anfragen!



Schwiebacher Abbruch Technik

Werkstatt • Lager • Service seit 1977

D-82229 Seefeld (bei München)

Graf-Toerring-Seefeld-Strasse 9b / 17

Tel. 08152 / 998 969-0 Fax.- 9

T.48/T.50 LADE-SCHWENK-LÖFFEL *optimal**

(2 Zylinder stehend, Holland-Profil) für Bagger von 7,5 bis 12,5 to

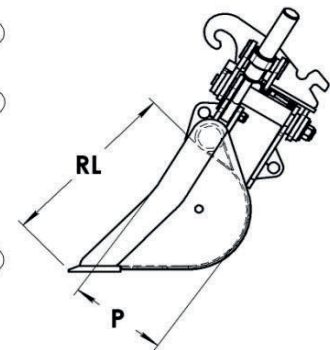
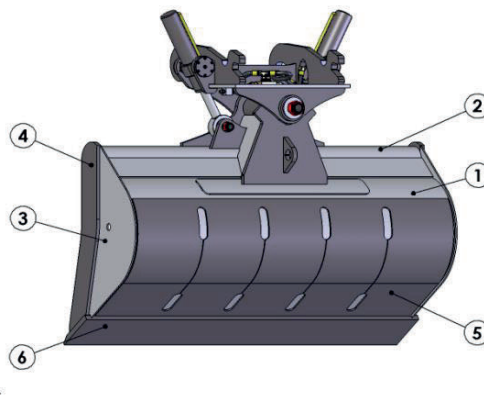
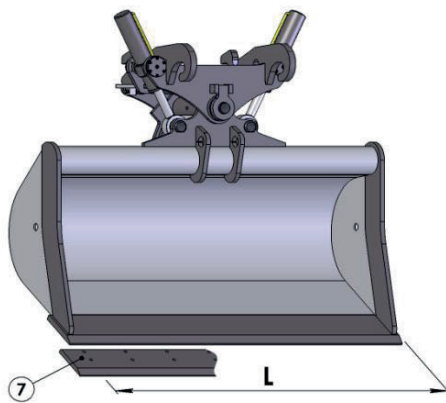
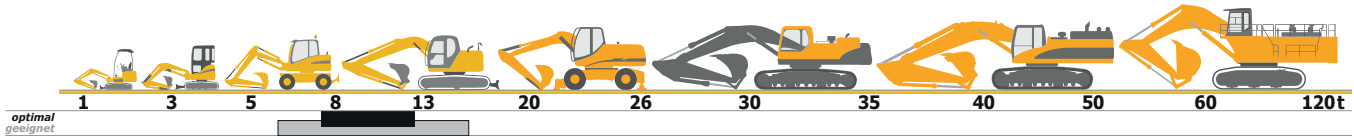

Klasse Class Classe	Bestell Nr. Code Code	L mm.	Cap. SAE Lt.	Anz. Zylinder Cylinders Verins	Gewicht kg Weight Poids	RL mm.	P mm.	Preis Price List Tarif	Unterschraubmesser Bolt on Blade Lame boulonnées
T.48 T.50 7,5-12,5 ton	T48ORO140	1400	348	2	428	649	358	4.731,00 EUR	234,00 EUR
	T48ORO150	1500	375	2	440				
	T48ORO160	1600	403	2	456				
	T48ORO180	1800	458	2	483				
	T48ORO200	2000	513	2	510				
		1	2	3	4	5	6	/	7 Optional
Material	Material Matériel	Fe 510	Fe 510	Fe 510	Hardox	Fe 510	Hb 400	/	Hb 400
Materialstärke	Thickness E spessore	6 mm	114.3 x 12.5 mm	8 mm	15 mm	6 mm	200 x 20 mm	/	200 x 20 mm

*optimal = für Bagger von 7,5 bis 12,5 t mit Standard-Ausrüstung.

T.48 Atlas 1004/1102D; Benati 3.06/3.07R/3.08R/5.08/5.10; BobCAT 442; Case 488/9007/WX 90/WX 95/CX 75/CX 75SR/CX 80; Caterpillar E 307/E 70/E 70B/307C/308C CR; Daewoo Doosan 070-III/075-V; Eurocomach ES-800; Euromach 8500/TIGRONE; Fai 409/410C/W/750 C/900CH/GTH/GTV; Fiat Hitachi EX 60/EX 60.5/E X 60WD/FH 65W/EX 75U R/EX 75US/FH 85W/FH 9 0WT/FH 95; Fiat Kobelco E 70SR/E 80 SR; Hanix H 75B; Hitachi ZX 70/ZX 80SB/ZX 85US; Hydrema R 800; Hyundai R 95W-3; Ihi-Imer 80 NX/80NX3; JCB JS 70/JZ 70/8080ZTS; Kamo MOBIL 70; Kobelco SK 75UR/SK 80 MSR/YUTANI SK 03; Komatsu PC 75/75R/PC 75R2/PC 75UU/PC 75UU/PC 78MR6/PC 95R/PC 95R2/PW 75/PW 95/PC 58U; Kubota KX 251; Kramer 806/808; Liebherr A 307/A 308/R 308; Macmoter M 7/M 8/M 8M/M 10/BW 75/BW 95; Mecalac 11CX/12CX/12MX/12MSX; Neuson 7002RD/8002RD/75Z3; New Holland E 80MS R; O&K 2.8C/2.8D/MH 2.5; Schaeff HR 41/HML 40/HML 41/HML 42/HS 40A/B/D/HS 41/SKB 1000; Takeuchi TB 80FR/TB 175/TB 175W; Terex 960/970; Venieri VF 12.23; Volvo E CR 88; Yanmar Vio 75/Vio 100.

T.50 Akermann H 3B; Atlas 1104/1204; Benati 3.12R; Benfra 3R/3C; BobCAT 444; Case WX 120; Cosmoter BAT 10; Euromach 9000/9500; Fiat Hitachi FH 115W/FH 120W/EX 100/FH 115; Fiat Kobelco E 115SR/EX 125W; Hitachi ZX 110; Hyundai R110LC7; JCB JS 110; Kobelco SK 100/SK 115SR; Komatsu PC 110R/PC 110R1/PW 110R/PC 120; Laltesi 40/111; Liebherr A 309/A 310/A 311; Macmoter M 12M/BW 110; Mecalac 14M X/14MBX; MF 250; Neuson 1002RD/12002RD; New Holland MH 2.6/MH 3.6/E 115SR; O&K MH 2.10/MH 3.5; PMI 450/810R/913; Terex HR 42.

geeignet = für Bagger von 6,0 bis 16 t je nach Ausrüstung. Andere Klassen/Größen bedingt geeignet. Bei Bedarf bitte anfragen!



T.55 LADE-SCHWENK-LÖFFEL *optimal** (2 Zylinder stehend, Holland-Profil) für Bagger von 12,5 bis 16 to

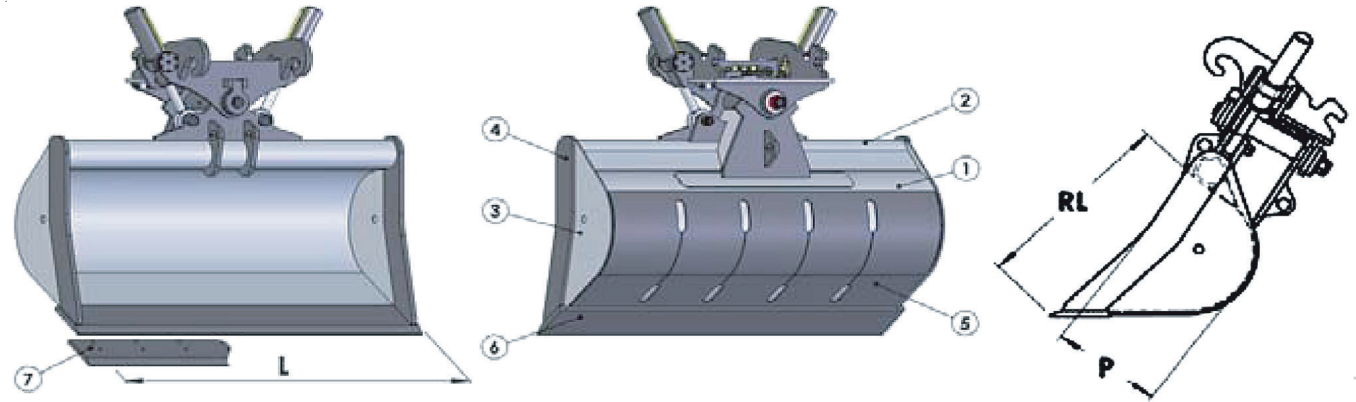
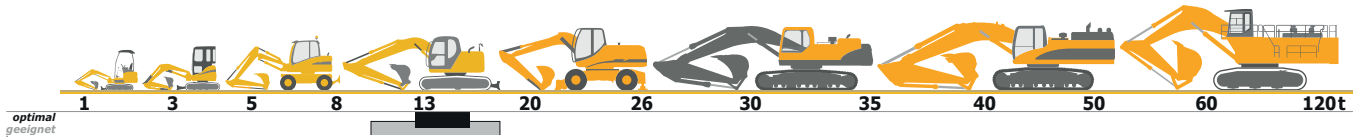

Klasse Class Classe	Bestell Nr. Code Code	L mm.	Cap. SAE Lt.	Anz. Zylinder Cylinders Vérins	Gewicht kg Weight Poids	RL mm.	P mm.	Preis Price List Tarif	Unterschraubmesser Bolt on Blade Lame boulonnées
T.55 12,5-16 ton	T55ORO150	1500	585	2	730	830	445	/	/
	T55ORO160	1600	629	2	750				
	T55ORO180	1800	717	2	790				
	T55ORO200	2000	805	2	832				
	T55ORO220	2200	893	2	873				
		1	2	3	4	5	6	7	Optional
Material	Material Matériel	Fe 510	Fe 510	Fe 510	Hardox	Fe 510	Hb 400	/	Hb 400
Materialstärke	Thickness Espessure	8 mm	127 x 14.2 mm	8 mm	20 mm	8 mm	250 x 25 mm	/	250 x 25 mm

*optimal = für Bagger von 12,5 bis 16 t mit Standard-Ausrüstung.

Akermann H 5; **Atlas** 1302/1304M/1304LC/1404M/14 04LC; **Benati** 90/120/140/145/3.15/3.16/3.17; **Benfra** 4R/4C/5/9.05/9.06;
Case 588/9013/CX 130/CS 135SR/WX 125/WX 145; **Caterpillar** EB 120/205/206/M 312/M 313C/M 315/311C/312C/314C;
Cosmoter BAT 12/14; **Daewoo Doosan** DH 130.2/S 110/S 130W-III/S 1 30LCV/S 140WV/S 160W V/S 140LCV/S 150LCV;
Fai 1000 C/CH/GTH; **Fiat Hitachi** FH 120/FH 125W/FH 130.3/EX 135; **Fiat Kobelco** E 13 5/E 135SR/E 145W;
Fiat-Allis E 12/FE 14/FE 16; **Ford** 42; **Furukawa** W 625E/W 630/W 635/W 725LS/W 730LS; **Halla** HE130W/H E 130LC;
Hitachi ZX 130/ZX 135US/ZX 130W; **Hydromac** H 75; **Hyundai** 120W/R 130W-3/140W-7/R 130LC-3/R 140LC-7;
JCB JS 130/JS 130W/JS 140/JS 145W; **Kobelco** SK 120/SK 135SRLC/90 3B; **Komatsu** PC 130/PW 130-7/PC 138US-2/PC 150.3;
Laltesì 50/221/222; **Liebherr** R 310B/R 312/A 312 LIT/A 314/A 316/A 900; **Mecalac** 714MC/714MW; **MF** 330;
New Holland E 145/E 135SRLC/SRL/MH CITY/MH 4.6; **O&K** RH 4/RH 4PLUS/RH 4PMS/RH CITY/MH 4/MH CITY/MHS/
MH PLUS/RH 4.5/RH PLUS; **PMI** 700/8.15/8.17; **Poclair** TCS 45/60; **ROCK** 75; **Samsung** SE 130LC.2/SE 130W.3;
Takeuch TB 1140; **Volvo** EC 130/EW 130/EC 140B/EW 140B/EC 150/EW 160 B.

geeignet = für Bagger von 10 bis 18 t je nach Ausrüstung.
 Andere Klassen/Größen bedingt geeignet. Bei Bedarf bitte anfragen!



Schwiebacher Abbruch Technik

Werkstatt • Lager • Service seit 1977

D-82229 Seefeld (bei München)

Graf-Toerring-Seefeld-Strasse 9b / 17

Tel. 08152 / 998 969-0 Fax.- 9

T.60 LADE-SCHWENK-LÖFFEL *optimal**

(2 Zylinder stehend, Holland-Profil) für Bagger von 16 bis 19 to

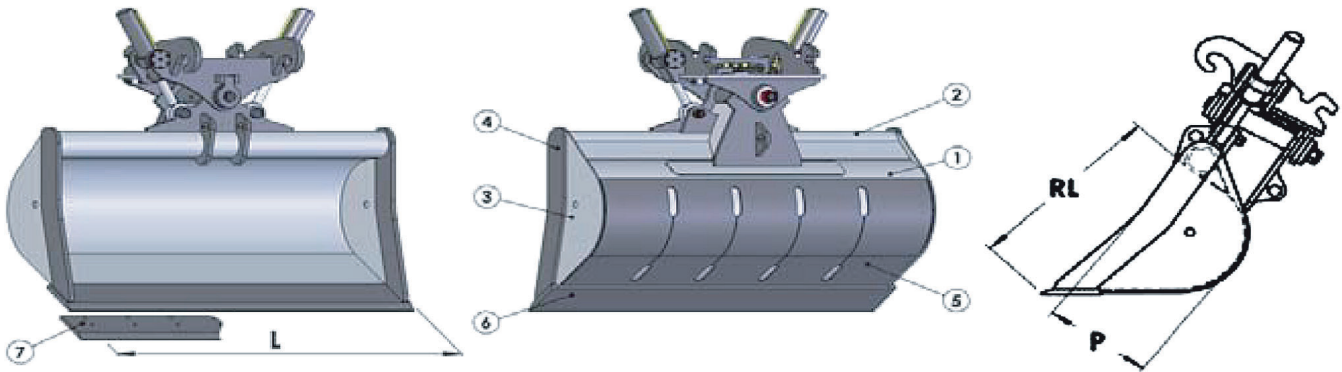
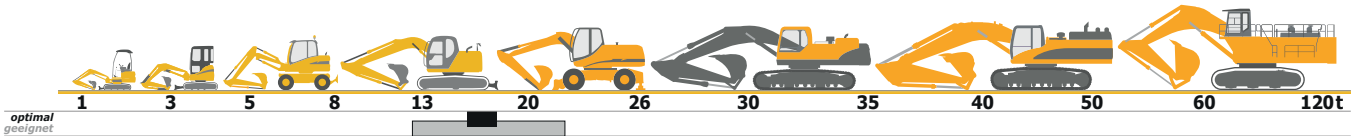

Klasse Class Classe	Bestell Nr. Code Code	L mm.	Cap. SAE Lt.	Anz. Zylinder Cylinders Vérins	Gewicht kg Weight Poids	RL mm.	P mm.	Preis Price List Tarif	Unterschraubmesser Bolt on Blade Lame boulonnées
T.60 16-19 ton	T60ORO150	1500	677	2	753	900	473		
	T60ORO160	1600	730	2	775				
	T60ORO180	1800	832	2	820				
	T60ORO200	2000	935	2	862				
	T60ORO220	2200	1038	2	905				
		1	2	3	4	5	6	/	7 Optional
Material	<i>Material Matériel</i>	Fe 510	Fe 510	Fe 510	Hardox	Fe 510	Hb 400	/	Hb 400
Materialstärke	<i>Thickness E spessore</i>	8 mm	127 x 14.2 mm	8 mm	20 mm	8 mm	250 x 25 mm	/	250 x 25 mm

*optimal = für Bagger von 16 bis 19 t mit Standard-Ausrüstung.

Akermann H 7B/H 7C; **Atlas** 1604M/1604LC/1622; **Benati** 160/3.18; **Benfra** 6C/7R/7.07/7.08/9.07/9.08/9.20;
Case 688/688B/788/CX 160/WX 150/WX 165/WX 170/CX 180; **Caterpillar** 211/212/213B/214/214B/315/317/318/M 316C/
M 318C/315C; **Cosmoter** BAT 16; **Daewoo Doosan** DH 170/DH 180/S 170III/V/S 175LCV/S 180WV; **FAI** 1100;
Fiat Hitachi FH 150.3/EX 165/FH 150 W.2/FH 150W.3; **Fiat Kobelco** E 165 LC/E 175W; **Fiat-Allis** FE 18; Ford 44/45;
Furukawa 635E; **Hitachi** ZX 160LC/ZX 180LC/ZX 160W/ZX180W; **Hydromac** H 85; **Hyundai** R 160LC-3/7/R 170W-3/R 180LC-3/7;
JCB JS 150/JS 160LC/JS 160W/JS 175W/JS 180LC; **Kobelco** SK 150/SK 160LC/904/905B/SK 170LC;
Komatsu PC 160-7/PW 160-7/PW 170/PC 180-7/PW 1 80-7; **Laltes** 80/341/341HD;
Liebherr A 9 00C/A 900B LIT/A 902 LIT/A 314 LIT/A 316 LIT/R 317; **MF** 350D/350E;
New Holland E 175/MH PL US/MH PLUS C/MH 5.6;
O&K RH 5/RH 5PLUS/RH 5 PMS/MH 5/MH 5PMS/RH 5.5; **PMI** 900/8.18; **Poclair** 61/75/688; ROCK 100;
Samsung SE 170W.3; **Volvo** EC 160B/EC 170/EW 170/EC 180B/EW 180B.

geeignet = für Bagger von 12,5 bis 22 t je nach Ausrüstung.
Andere Klassen/Größen bedingt geeignet. Bei Bedarf bitte anfragen!



Schwiebacher Abbruch Technik

Werkstatt • Lager • Service seit 1977

D-82229 Seefeld (bei München)

Graf-Toerring-Seefeld-Strasse 9b / 17

Tel. 08152 / 998 969-0 Fax.- 9

T.65 LADE-SCHWENK-LÖFFEL *optimal**

(2 Zylinder stehend, Holland-Profil) für Bagger von 19 bis 23 to

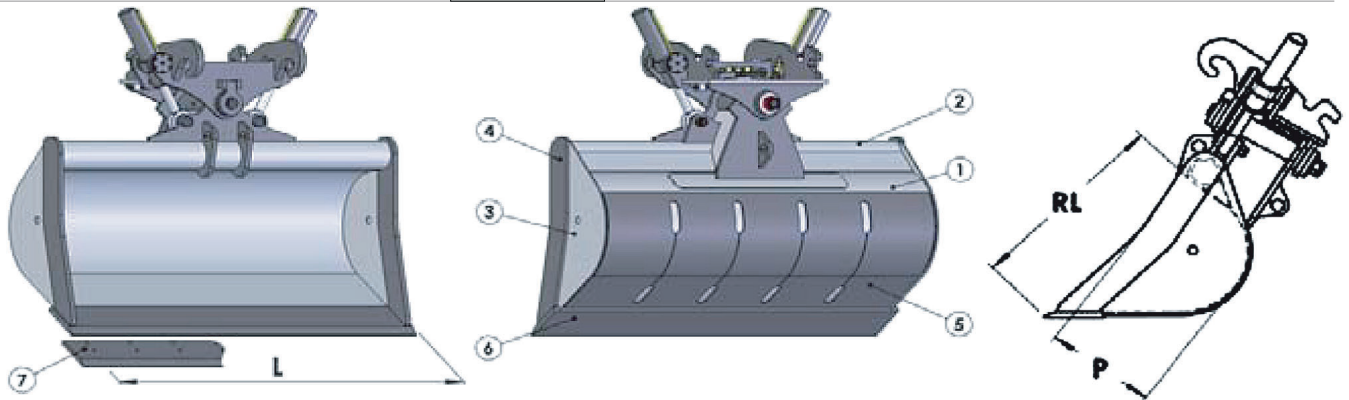
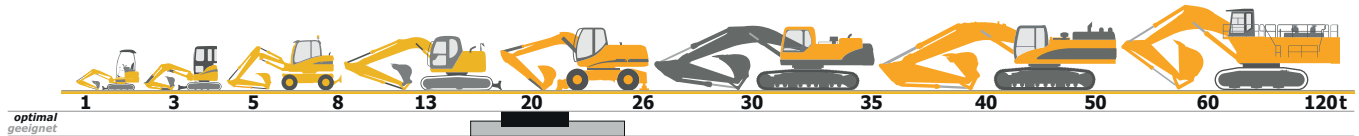

Klasse Class Classe	Bestell Nr. Code Code	L mm.	Cap. SAE Lt.	Anz. Zylinder Cylinders Vérins	Gewicht kg Weight Poids	RL mm.	P mm.	Preis Price List Tarif	Unterschraubmesser Bolt on Blade Lame boulonnées
T.65 19-23 ton	T65ORO160	1600	820	2	870	956	515		
	T65ORO180	1800	937	2	922				
	T65ORO200	2000	1054	2	975				
	T65ORO220	2200	1171	2	1025				
	T65ORO240	2400	1288	2	1075				
	T65ORO250	2500	1346	2	1105				
		1	2	3	4	5	6	/	7 Optional
Material	Material Matériel	Fe 510	Fe 510	Fe 510	Hardox	Fe 510	Hb 400	/	Hb 400
Materialstärke	Thickness Espessure	8 mm	152.4 x 16 mm	8 mm	25 mm	8 mm	270 x 32 mm	/	250 x 25 mm

*optimal = für Bagger von 19 bis 23 t mit Standard-Ausrüstung.

Atlas 1702D/1704D/1704LC; **Benati** 190CSB/3.20/3.21; **Benfra** 8C/9.09; **Case** 888/888B/988/9021/CX 210/WX 185/WX 200/WX 210; **Caterpillar** 215C/219C/318B/319C/M 320/M 322C; **Cosmoter** BAT 18C; **Daewoo Doosan** S 200WIII/V/S 210WV/DH 220LC/S2 20LCVIII/V/S 225LCV; **FAI** 1200/1300CH/GTH/1400/1500; **Fiat Hitachi** FH 200W.3/EX 200/EX 215; **Fiat Kobelco** E 200SR/E 215 E; **Fiat-Allis** FE 20; **Ford** 47; **Furukawa** 640E/W 735LS/W 738LS; **Hitachi** ZX 210/ZX 210LC/ZX 21 0N/ZX 210W/ZX 225USR/ZX 225USRLC/ZX 225USLC; **Hydromac** H 95/H 105/H 115; **Hyundai** R 200W/R 200LC/R 210LC-3/7; **JCB** JS 200W/JS 200 LC/JS 210/JS 220; **Kobelco** SK 200/SK 210LC/907/SK 200SR; **Komatsu** PC 200/PC 210/PC 228US-3/P W 200-7/PW 210/PW 220-7; **Laltesi** 441HD; **Liebherr** A 904C/A 904 LIT/A 912 LIT/A 914B/A 914 LIT/R 900B/C LIT/R 904 L IT; **MF** 450D/450E; **New Holland** E 215/E/LC/E 195EL/LC/E 200SR/SRLC/MH 6.6/MH 8.6; **O&K** RH 6B/C/D/E/F/MH 6B/C/D/E/F/RH 6 COMPAC; **PMI** 822/9.21/9.22; **Poclair** 81/888; **ROCK** 130/135; **Samsung** SE 210LC.3/SE 210W.2; **Terex** TC 210 LC/TC 210NLC/TC 225LC/TC 225NLC; **Volvo** EC 200/EW 200/EC 210B.

geeignet = für Bagger von 16 bis 25 t je nach Ausrüstung.
Andere Klassen/Größen bedingt geeignet. Bei Bedarf bitte anfragen!



Schwiebacher Abbruch Technik

Werkstatt • Lager • Service seit 1977

D-82229 Seefeld (bei München)

Graf-Toerring-Seefeld-Strasse 9b / 17

Tel. 08152 / 998 969-0 Fax.- 9

T.66 LADE-SCHWENK-LÖFFEL *optimal**

(2 Zylinder stehend, Holland-Profil) für Bagger von 23 bis 26 to

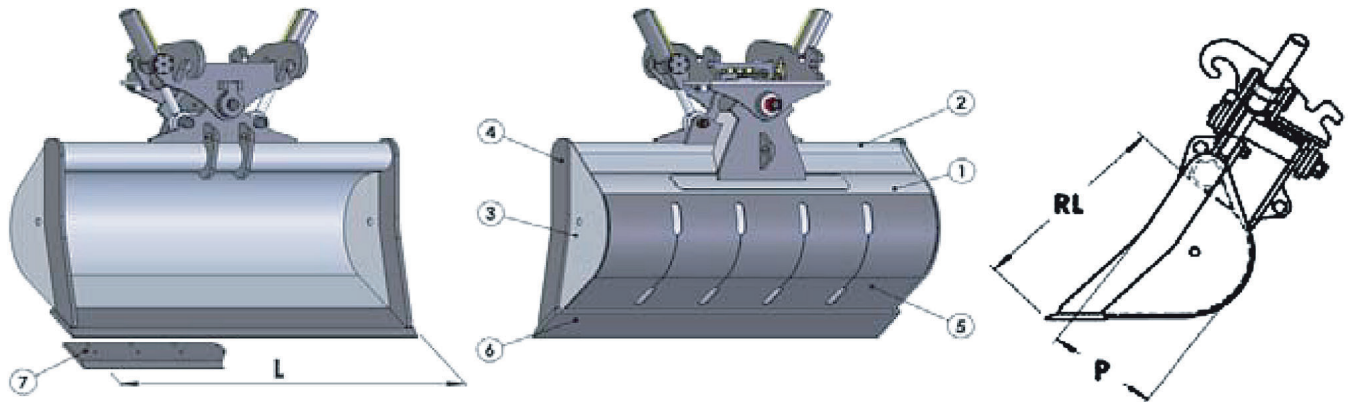
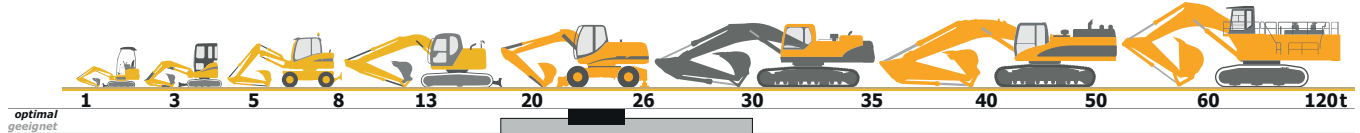

Klasse Class Classe	Bestell Nr. Code Code	L mm.	Cap. SAE Lt.	Anz. Zylinder Cylinders Vérins	Gewicht kg Weight Poids	RL mm.	P mm.	Preis Price List Tarif	Unterschraubmesser Bolt on Blade Lame boulonnées
T.66 23-23 ton	T66ORO160	1600	930	2	890	1030	540		
	T66ORO180	1800	1066	2	945				
	T66ORO200	2000	1200	2	997				
	T66ORO220	2200	1334	2	1050				
	T66ORO240	2400	1470	2	1105				
	T66ORO250	2500	1535	2	1130				
		1	2	3	4	5	6	/	7 Optional
Material	Material Matériel	Fe 510	Fe 510	Fe 510	Hardox	Fe 510	Hb 400	/	Hb 400
Materialstärke	Thickness Espessure	8 mm	152,4 x 16 mm	8 mm	25 mm	8 mm	270 x 32 mm	/	250 x 25 mm

*optimal = für Bagger von 23 bis 26 t mit Standard-Ausrüstung.

Akermann H 10B; **Atlas** 1802; **Benati** 3.22/3.22B; **Benfra** 10C/9.10/9.24;
Case 1088/1188/CX 225/CX 255 SR/CX 230/CX 240/WX 240; **Caterpillar** 215D/219D/320B/C/M 325C/321C;
Daewoo Doosan S 240/S 250/S 255LCV; **FAI** 1600; **Fiat Hitachi** FH 220.3/FH 240.3/EX 235/EX 255;
Fiat Kobelco EX 255EL/LC/E 235E/E 235SR; **Fiat-Allis** FE 24; **Ford** 48; **Furukawa** 740LS/640E;
Halla HE 220LC; **Hitachi** ZX 240/ZX 250/ZX 250LC/ZX 250LCN; **Hydromac** H 135/H 145;
Hyundai 228LC/R 250LC-3/7; **JCB** JS 235/JS 240/JS 260; **Kobelco** SK 220/SK 235 R/SK 250LC;
Komatsu PC 220/PC 230N-7/PC 240-7; **Lalesi** 420/500HD; **Liebherr** A 924B/A 924 LIT/R 912 LIT/R 914 LIT/R 914B LIT;
New Holland E 245/E 265EL/LC/E 235SRNLC/SRLC; **O&K** RH 6PMS/RH 6.20/RH 6.22/RH 8PMS/MH 8.6/RH 6.5;
PMI 1000/1200/8.25/9.25; **Poclair** 90/115; **Samsung** SE 240LC.3;
Terex TC 240 LC/TC 240NLC/TC 260LC/TC 260NLC; **Volvo** EC 230/EW 230/EC 240B.

geeignet = für Bagger von 18 bis 30 t je nach Ausrüstung.
 Andere Klassen/Größen bedingt geeignet. Bei Bedarf bitte anfragen!



T.68 LADE-SCHWENK-LÖFFEL *optimal** (2 Zylinder stehend, Holland-Profil) für Bagger von 26 bis 36 to

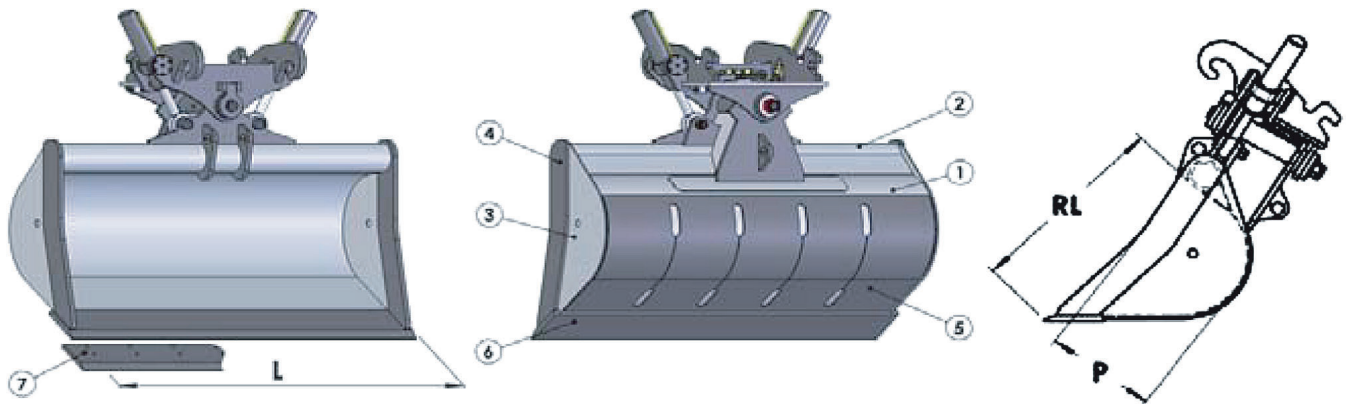
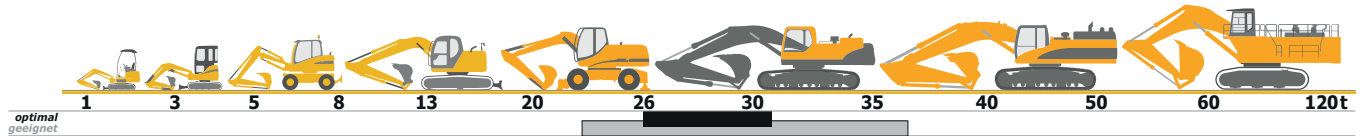

Klasse Class Classe	Bestell Nr. Code Code	L mm.	Cap. SAE Lt.	Anz. Zylinder Cylinders Vérins	Gewicht kg Weight Poids	RL mm.	P mm.	Preis Price List Tarif	Unterschraubmesser Bolt on Blade Lame boulonnées
T.68 26-31 ton	T68ORO160	1600	1177	2	1330	1155	625	/	Hb 400
	T68ORO180	1800	1350	2	1405				
	T68ORO200	2000	1522	2	1480				
	T68ORO220	2200	1694	2	1555				
	T68ORO240	2400	1867	2	1230				
	T68ORO250	2500	1953	2	1665				
		1	2	3	4	5	6	/	7 Optional
Material	Material Matériel	Fe 510	Fe 510	Fe 510	Hardox	Fe 510	Hb 400	/	Hb 400
Materialstärke	Thickness Espessure	10 mm	177.8 x 20 mm	10 mm	30 mm	10 mm	300 x 35 mm	/	250 x 25 mm

*optimal = für Bagger von 26 bis 31 t mit Standard-Ausrüstung.

Akermann H 14B; **Atlas** 1804/1804M/180 4LC/1902; **Benati** 230CSB/270CSB/370/3.28/3.30;
Benfra 12C/9.11/9.12; **Case** 1288CK/CX 290; **Caterpillar** 225D/229D/231/322B/322C/323/325B/C/D;
Cosmoter BAT 25C; **Daewoo Doosan** DH 280/280 LCIII/V/290LCV/S 300LCV; **Fiat Hitachi** FH 270.3/ EX 285;
Fiat Kobelco EX 285LC; **Fiat-Allis** FE 28; **Ford** 50; **Furukawa** 645LS; **Hitachi** ZX 28 0LC/ZX 280LCN;
Hydromac H 150/H 180; **Hyundai** 280LC/290 LC-3/7; **JCB** JS 3 00/JS 330; **Kobelco** SK 300/909;
Komatsu PC 270/PC 280/PC 290-7/PC 300; **Laltes** 541; **Liebherr** A 932 LIT/A 934 LIT/R 924B LIT/R 924 LIT;
MF 550; **New Holland** E 305EL/LC; **O&K** RH 9E/F/G/PMS/RH 9.5/RH 8.5; **PMI** 1300/1500/8.30/8.34/9.26/9.30/9.35;
Poclair 125; **ROCK** 150; **Samsung** SE 280 LC.2; **Volvo** EC 280/EC 290B.

geeignet = für Bagger von 22 bis 36 t je nach Ausrüstung.
 Andere Klassen/Größen bedingt geeignet. Bei Bedarf bitte anfragen!



Schwiebacher Abbruch Technik

Werkstatt • Lager • Service seit 1977

D-82229 Seefeld (bei München)

Graf-Toerring-Seefeld-Strasse 9b / 17

Tel. 08152 / 998 969-0 Fax.- 9

T.70 LADE-SCHWENK-LÖFFEL *optimal** (2 Zylinder stehend, Holland-Profil) für Bagger von 31 bis 43 to

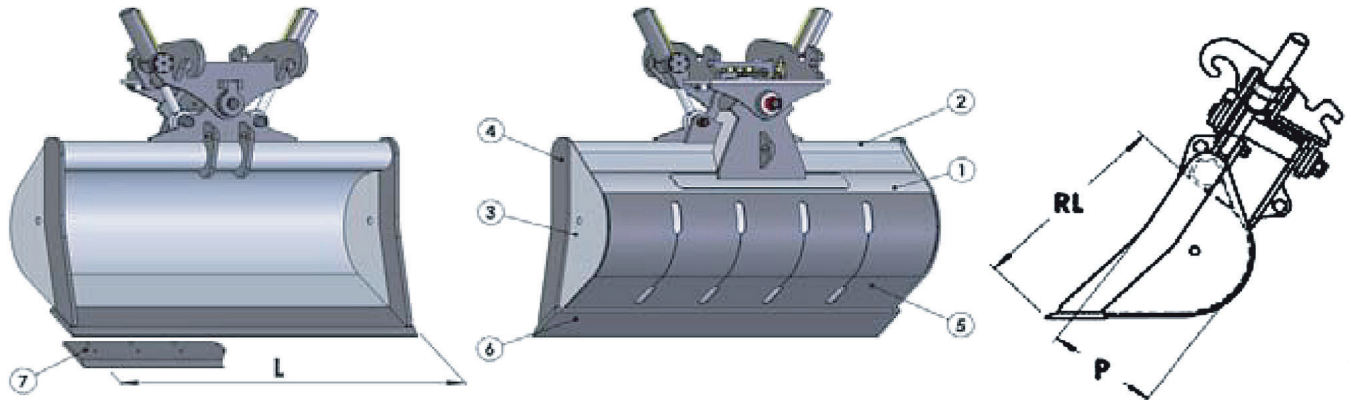
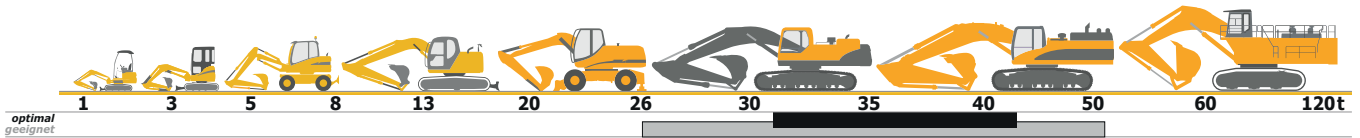

Klasse Class Classe	Bestell Nr. Code Code	L mm.	Cap. SAE Lt.	Anz. Zylinder Cylinders Vérins	Gewicht kg Weight Poids	RL mm.	P mm.	Preis Price List Tarif	Unterschraubmesser Bolt on Blade Lame boulonnées
T.70 31-43 ton	T70ORO160	1600	1330	2	1370	1240	660		
	T70ORO180	1800	1528	2	1450				
	T70ORO200	2000	1725	2	1525				
	T70ORO220	2200	1922	2	1605				
	T70ORO240	2400	2118	2	1685				
	T70ORO250	2500	2216	2	1720				
		1	2	3	4	5	6	/	7 Optional
Material	Material Matériel	Fe 510	Fe 510	Fe 510	Hardox	Fe 510	Hb 400	/	Hb 400
Materialstärke	Thickness E spessore	10 mm	177.8 x 20 mm	10 mm	30 mm	10 mm	300 x 35 mm	/	250 x 25 mm

*optimal = für Bagger von 31 bis 43 t mit Standard-Ausrüstung.

Akermann H 16C; **Atlas** 2004; **Benati** 335/450/310CSB; **Benfra** 9.32; **Case** 1488, 9033/CX 330/CX 350;
Caterpillar 330B/C/D/E; **Daewoo Doosan** DH 320/S 330III/V/S 360LCIII/S 340LCV;
Fiat Hitachi FH 300.2/FH 330.3/EX 355; **Fiat Kobelco** EX 355EL/LC/BEN; **Furukawa** 650E; **Halla** HE 360LCH;
Hitachi ZX 350LC/ZX 350LCN; **Hydromac** H 200; **Hyundai** H 230/H 270/R 320LC-3/7/R 360LC-3/7;
Kobelco SK 330LC/912; **Komatsu** PC 340-7/PC 360; **Laltes** 350 HD/551HD;
Liebherr A 944 HD LIT/R 934B LIT/R 942 LIT/R 944 LIT/R 944B LIT; **New Holland** E 335LC/NLC/E 3 85EL/LC/BEH;
O&K RH 12.5/RH 14; **PMI** 14855; **Poclair** 170; **ROCK** 200; **Samsung** SE 350LC.2; **Volvo** EC 330B/EC 340/EC 360B.

geeignet = für Bagger von 26 bis 50 t je nach Ausrüstung.
 Andere Klassen/Größen bedingt geeignet. Bei Bedarf bitte anfragen!