



Schwiebacher Abbruch Technik

Werkstatt • Lager • Service seit 1977

D-82229 Seefeld (bei München)

Graf-Toerring-Seefeld-Strasse 9b / 17

Tel. 08152 / 998 969-0 Fax.- 9

T.48/T.50 GRABENRÄUM-LÖFFEL (flaches Profil) optimal* für Bagger von 7,5 bis 12,5 to

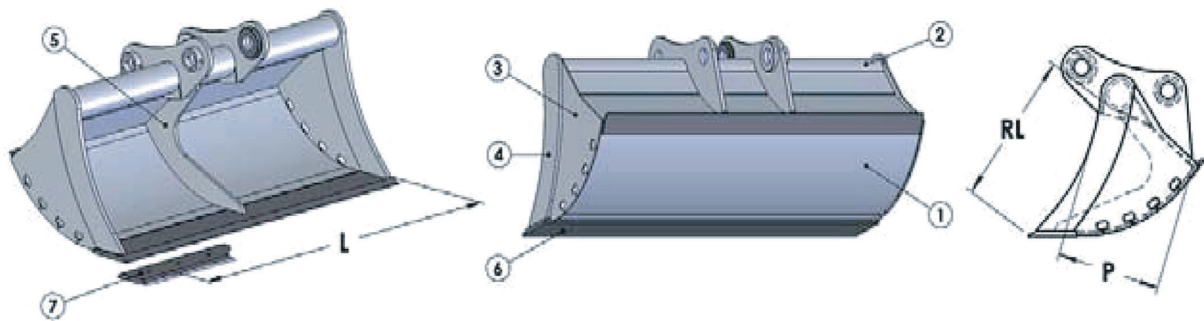
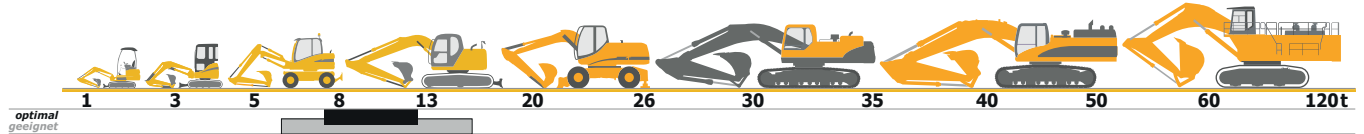

Klasse Class Classe	Bestell Nr. Code Code	L mm.	Cap. SAE Lt.	Gewicht kg Weight Poids	RL mm.	P mm.	Preis € Price List Tarif	Unterschraubmesser Bolt on Blade Lame boulonnées
T.48 T.50 7,1-12,5 ton	T48PFZ140	1400	287	217	550	337		
	T48PFZ150	1500	310	229				
	T48PFZ160	1600	332	241				
	T48PFZ180	1800	377	265				
	T48PFZ200	2000	422	289				
		1	2	3	4	5	6	7 Optional
Material	Material Matériel	Fe 510	Fe 510	Fe 510	Fe 510	Fe 510	Hb 400	Hb 400
Stärke	Thickness Espessure	8 mm	114.3 x 12.5 mm	6 mm	12 mm	15 mm	200 x 20 mm	150 x 20 mm

*optimal = für Bagger von 7,5 bis 12,5 t mit Standard-Ausrüstung.

T.48 Atlas 1004/1102D; Benati 3.06/3.07R/3.08R/5.08/5.10; BobCAT 442; Case 488/9007/WX 90/WX 95/CX 75/CX 75SR/CX 80; Caterpillar E 307/E 70/E 70B/307C/308C CR; Daewoo Doosan 070-III/075-V; Eurocomach ES-800; Euromach 8500/TIGRONE; Fai 409/410C/W/750 C/900CH/GTH/GTV; Fiat Hitachi EX 60/EX 60.5/E X 60WD/FH 65W/EX 75U R/EX 75US/FH 85W/FH 9 0WT/FH 95; Fiat Kobelco E 70SR/E 80 SR; Hanix H 75B; Hitachi ZX 70/ZX 80SB/ZX 85US; Hydrema R 800; Hyundai R 95W-3; Ihi-Imer 80 NX/80NX3; JCB JS 70/JZ 70/8080ZTS; Kamo MOBIL 70; Kobelco SK 75UR/SK 80 MSR/YUTANI SK 03; Komatsu PC 75/75R/PC 75R2/PC 75UU/PC 75UU/PC 78MR6/PC 95R/PC 95R2/PW 75/PW 95/PC 58U; Kubota KX 251; Kramer 806/808; Liebherr A 307/A 308/R 308; Macmoter M 7/M 8/M 8M/M 10/BW 75/BW 95; Mecalac 11CX/12CX/12MX/12MSX; Neuson 7002RD/8002RD/75Z3; New Holland E 80MS R; O&K 2.8C/2.8D/MH 2.5; Schaeff HR 41/HML 40/HML 41/HML 42/HS 40A/B/D/HS 41/SKB 1000; Takeuchi TB 80FR/TB 175/TB 175W; Terex 960/970; Venieri VF 12.23; Volvo E CR 88; Yanmar Vio 75/Vio 100.

T.50 Akermann H 3B; Atlas 1104/1204; Benati 3.12R; Benfra 3R/3C; BobCAT 444; Case WX 120; Cosmoter BAT 10; Euromach 9000/9500; Fiat Hitachi FH 115W/FH 120W/EX 100/FH 115; Fiat Kobelco E 115SR/EX 125W; Hitachi ZX 110; Hyundai R110LC7; JCB JS 110; Kobelco SK 100/SK 115SR; Komatsu PC 110R/PC 110R1/PW 110R/PC 120; Laltesi 40/111; Liebherr A 309/A 310/A 311; Macmoter M 12M/BW 110; Mecalac 14M X/14MBX; MF 250; Neuson 1002RD/12002RD; New Holland MH 2.6/MH 3.6/E 115SR; O&K MH 2.10/MH 3.5; PMI 450/810R/913; Terex HR 42.

geeignet = für Bagger von 6,0 bis 16 t je nach Ausrüstung. Andere Klassen/Größen bedingt geeignet. Bei Bedarf bitte anfragen!



SAT®

Schwiebacher Abbruch Technik

Werkstatt • Lager • Service seit 1977

D-82229 Seefeld (bei München)

Graf-Toerring-Seefeld-Strasse 9b / 17

Tel. 08152 / 998 969-0 Fax.- 9

T.55/T.60 GRABENRÄUM-LÖFFEL (flaches Profil) optimal* für Bagger von 12,5 bis 19 to

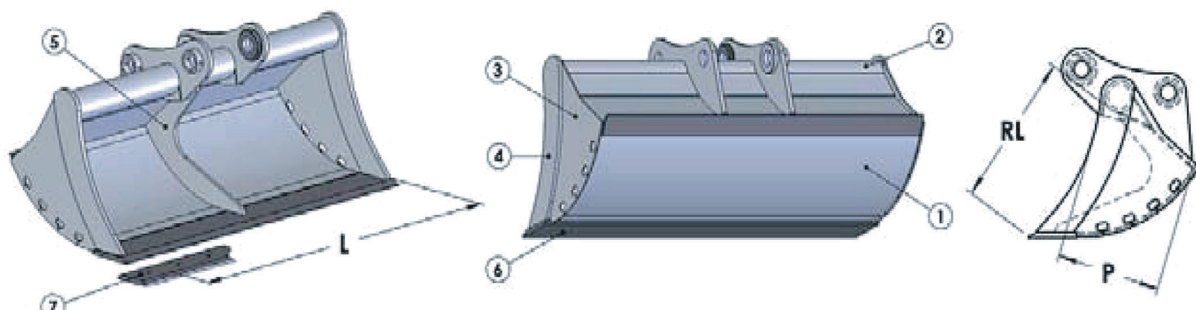
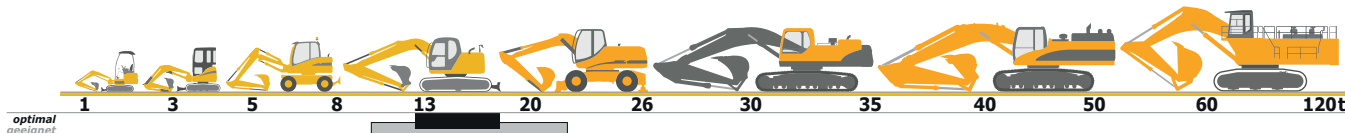

Klasse Class Classe	Bestell Nr. Code Code	L mm.	Cap. SAE Lt.	Gewicht kg Weight Poids	RL mm.	P mm.	Preis € Price List Tarif	Unterschraubmesser Bolt on Blade Lame boulonnées
T.55 T.60 12,5-19 ton	T55PFZ150	1500	353	305	570	345		
	T55PFZ180	1800	431	347				
	T55PFZ200	2000	483	374				
	T55PFZ220	2200	534	402				
		1	2	3	4	5	6	7 Optional
Material	Material <i>Matériel</i>	Fe 510	Fe 510	Fe 510	Fe 510	Fe 510	Hb 400	Hb 400
Stärke	Thickness <i>Espessore</i>	8 mm	127 x 14.2 mm	6 mm	20 mm	15 mm	200 x 25 mm	200 x 20 mm

*optimal = für Bagger von 12,5 bis 19 t mit Standard-Ausrüstung.

T.55 Akermann H 5; **Atlas** 1302/1304M/1304LC/1404M/14 04LC; **Benati** 90/120/140/145/3.15/3.16/3.17; **Benfra** 4R/4C/5/9.05/9.06; **Case** 588/9013/CX 130/CS 135SR/WX 125/WX 145; **Caterpillar** EB 120/205/206/M 312/M 313C/M 315/311C/312C/314C; **Cosmoter** BAT 12/14; **Daewoo Doosan** DH 130.2/S 110/S 130W-III/S 1 30LCV/S 140WV/S 160W V/S 140LCV/S 150LCV; **Fai** 1000 C/CH/GTH; **Fiat Hitachi** FH 120/FH 125W/FH 130.3/EX 135; **Fiat Kobelco** E 13 5/E 135SR/E 145W; **Fiat-Allis** E 12/FE 14/FE 16; **Ford** 42; **Furukawa** W 625E/W 630/W 635/W 725LS/W 730LS; **Halla** HE130W/H E 130LC; **Hitachi** ZX 130/ZX 135US/ZX 130W; **Hydromac** H 75; **Hyundai** 120W/R 130W-3/140W-7/R 130LC-3/R 140LC-7; **JCB** JS 130/JS 130W/JS 140/JS 145W; **Kobelco** SK 120/SK 135SRLC/90 3B; **Komatsu** PC 130/PW 130-7/PC 138US-2/PC 150.3; **Laltes** 50/221/222; **Liebherr** R 310B/R 312/A 312 LIT/A 314/A 316/A 900; **Mecalac** 714MC/714MW; **MF** 330; **New Holland** E 145/E 135SRLC/SRL/MH CITY/MH 4.6; **O&K** RH 4/RH 4PLUS/RH 4PMS/RH CITY/MH 4/MH CITY/MHS/ MH PLUS/RH 4.5/RH PLUS; **PMI** 700/8.15/8.17; **Poclain** TCS 45/60; **ROCK** 75; **Samsung** SE 130LC.2/SE 130W.3; **Takeuch** TB 1140; **Volvo** EC 130/EW 130/EC 140B/EW 140B/EC 150/EW 160 B.

T.60 Akermann H 7B/H 7C; **Atlas** 1604M/1604LC/1622; **Benati** 160/3.18; **Benfra** 6C/7R/7.07/7.08/9.07/9.08/9.20; **Case** 688/688B/ 788/CX 160/WX 150/WX 165/WX 170/CX 180; **Caterpillar** 211/212/213B/214/214B/315/317/318/M 316C/M 318C/315C; **Cosmoter** BAT 16; **Daewoo Doosan** DH 170/DH 180/S 170III/V/S 175LCV/S 180WV; **FAI** 1100; **Fiat Hitachi** FH 150.3/EX 165/ FH 150 W.2/FH 150W.3; **Fiat Kobelco** E 165 LC/E 175W; **Fiat-Allis** FE 18; **Ford** 44/45; **Furukawa** 635E; **Hitachi** ZX 160LC/ ZX 180LC/ZX 160W/ZX180W; **Hydromac** H 85; **Hyundai** R 160LC-3/7/R 170W-3/R 180LC-3/7; **JCB** JS 150/JS 160LC/JS 160W/ JS 175W/JS 180LC; **Kobelco** SK 150/SK 160LC/904/905B/SK 170LC; **Komatsu** PC 160-7/PW 160-7/PW 170/PC 180-7/PW 1 80-7; **Laltes** 80/341/341HD; **Liebherr** A 9 00C/A 900B LIT/A 902 LIT/A 314 LIT/A 316 LIT/R 317; **MF** 350D/350E; **New Holland** E 175/MH PL US/MH PLUS C/MH 5.6; **O&K** RH 5/RH 5PLUS/RH 5 PMS/MH 5/MH 5PMS/RH 5.5; **PMI** 900/8.18; **Poclain** 61/75/688; **ROCK** 100; **Samsung** SE 170W.3; **Volvo** EC 160B/EC 170/EW 170/EC 180B/EW 180B.

geeignet = für Bagger von 10 bis 22 t je nach Ausrüstung. Andere Klassen/Größen bedingt geeignet. Bei Bedarf bitte anfragen!



Schwienbacher Abbruch Technik

Werkstatt • Lager • Service seit 1977

D-82229 Seefeld (bei München)

Graf-Toerring-Seefeld-Strasse 9b / 17

Tel. 08152 / 998 969-0 Fax.- 9

T.65 GRABENRÄUM-LÖFFEL (flaches Profil) optimal* für Bagger von 19 bis 23 to

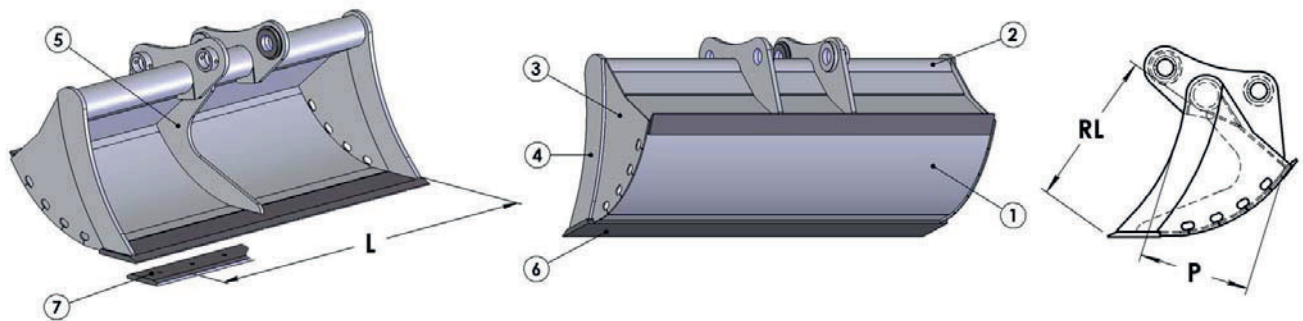
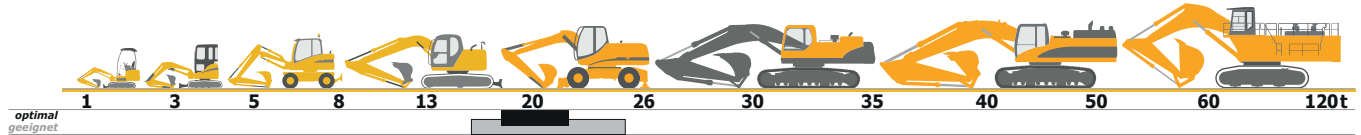

Klasse Class Classe	Bestell Nr. Code Code	L mm.	Cap. SAE Lt.	Gewicht kg Weight Poids	RL mm.	P mm.	Preis € Price List Tarif	Unterschraubmesser Bolt on Blade Lame boulonnées
T.65 19-23 ton	T65PFZ180	1800	554	416	650	381		
	T65PFZ200	2000	620	447				
	T65PFZ220	2200	687	477				
	T65PFZ240	2400	750	507				
	T65PFZ250	2500	783	522				
		1	2	3	4	5	6	7 Optional
Material	Material Matériel	Fe 510	Fe 510	Fe 510	Fe 510	Fe 510	Hb 400	Hb 400
Stärke	Thickness Espessure	8 mm	127 x 14.2 mm	8 mm	25 mm	20 mm	250 x 25 mm	200 x 20 mm

*optimal = für Bagger von 19 bis 23 t mit Standard-Ausrüstung.

Atlas 1702D/1704D/1704LC; **Benati** 190CSB/3.20/3.21; **Benfra** 8C/9.09; **Case** 888/888B/988/9021/CX 210/WX 185/WX 200/WX 210; **Caterpillar** 215C/219C/318B/319C/M 320/M 322C; **Cosmoter** BAT 18C; **Daewoo Doosan** S 200WIII/V/S 210WV/DH 220LC/S2 20LCVIII/V/S 225LCV; **FAI** 1200/1300CH/GTH/1400/1500; **Fiat Hitachi** FH 200W.3/EX 200/EX 215; **Fiat Kobelco** E 200SR/E 215 E; **Fiat-Allis** FE 20; **Ford** 47; **Furukawa** 640E/W 735LS/W 738LS; **Hitachi** ZX 210/ZX 210LC/ZX 21 0N/ZX 210W/ZX 225USR/ZX 225USRLC/ZX 225US/ZX 225USLC; **Hydromac** H 95/H 105/H 115; **Hyundai** R 200W/R 200LC/R 210LC-3/7; **JCB** JS 200W/JS 200 LC/JS 210/JS 220; **Kobelco** SK 200/SK 210LC/907/SK 200SR; **Komatsu** PC 200/PC 210/PC 228US-3/P W 200-7/PW 210/PW 220-7; **Laltesi** 441HD; **Liebherr** A 904C/A 904 LIT/A 912 LIT/A 914B/A 914 LIT/R 900B/C LIT/R 904 L IT; **MF** 450D/450E; **New Holland** E 215/E/LC/E 195EL/LC/E 200SR/SRLC/MH 6.6/MH 8.6; **O&K** RH 6B/C/D/E/F/MH 6B/C/D/E/F/RH 6 COMPAC; **PMI** 822/9.21/9.22; **Poclair** 81/888; **ROCK** 130/135; **Samsung** SE 210LC.3/SE 210W.2; **Terex** TC 210 LC/TC 210NLC/TC 225LC/TC 225NLC; **Volvo** EC 200/EW 200/EC 210B.

geeignet = für Bagger von 16 bis 25 t je nach Ausrüstung.
Andere Klassen/Größen bedingt geeignet. Bei Bedarf bitte anfragen!



T.66 GRABENRÄUM-LÖFFEL (flaches Profil) optimal* für Bagger von 22 bis 25 to

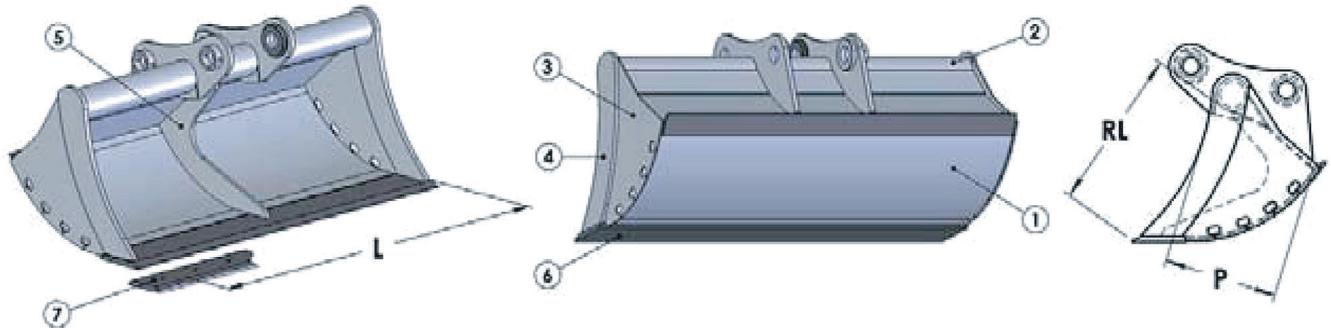
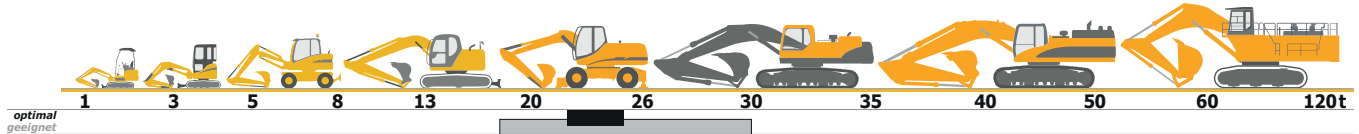

Klasse Class Classe	Bestell Nr. Code Code	L mm.	Cap. SAE Lt.	Gewicht kg Weight Poids	RL mm.	P mm.	Preis € Price List Tarif	Unterschraubmesser Bolt on Blade Lame boulonnées
T.66 23-26 ton	T66PFZ180	1800	738	489	750	460		
	T66PFZ200	2000	828	526				
	T66PFZ220	2200	917	562				
	T66PFZ240	2400	1007	598				
	T66PFZ250	2500	1052	617				
		1	2	3	4	5	6	7 Optional
Material	Material Matériel	Fe 510	Fe 510	Fe 510	Fe 510	Fe 510	Hb 400	Hb 400
Stärke	Thickness E spessore	8 mm	152.4 x 16 mm	8 mm	25 mm	20 mm	250 x 25 mm	200 x 20 mm

*optimal = für Bagger von 22 bis 25 t mit Standard-Ausrüstung.

Akermann H 10B; **Atlas** 1802; **Benati** 3.22/3.22B; **Benfra** 10C/9.10/9.24;
Case 1088/1188/CX 225/CX 255 SR/CX 230/CX 240/WX 240; **Caterpillar** 215D/219D/320B/C/M 325C/321C;
Daewoo Doosan S 240/S 250/S 255LCV; **FAI** 1600; **Fiat Hitachi** FH 220.3/FH 240.3/EX 235/EX 255;
Fiat Kobelco EX 255EL/LC/E 235E/E 235SR; **Fiat-Allis** FE 24; **Ford** 48; **Furukawa** 740LS/640E;
Halla HE 220LC; **Hitachi** ZX 240/ZX 250/ZX 250LC/ZX 250LCN; **Hydromac** H 135/H 145;
Hyundai 228LC/R 250LC-3/7; **JCB** JS 235/JS 240/JS 260; **Kobelco** SK 220/SK 235S R/SK 250LC;
Komatsu PC 220/PC 230N-7/PC 240-7; **Lalesi** 420/500HD; **Liebherr** A 924B/A 924 LIT/R 912 LIT/R 9 14 LIT/R 914B LIT;
New Holland E 245/E 265EL/LC/E 235SRNLC/SRLC; **O&K** RH 6PMS/RH 6.20/RH 6.22/RH 8PMS/MH 8.6/RH 6.5;
PMI 1000/1200/8.25/9.25; **Poclain** 90/115; **Samsung** SE 240LC.3;
Terex TC 240 LC/TC 240NLC/TC 260LC/TC 260NLC; **Volvo** EC 230/EW 230/EC 240B.

geeignet = für Bagger von 18 bis 30 t je nach Ausrüstung.
 Andere Klassen/Größen bedingt geeignet. Bei Bedarf bitte anfragen!



Schwienbacher Abbruch Technik

Werkstatt • Lager • Service seit 1977

D-82229 Seefeld (bei München)

Graf-Toerring-Seefeld-Strasse 9b / 17

Tel. 08152 / 998 969-0 Fax.- 9

T.68/T.70 GRABENRÄUM-LÖFFEL (flaches Profil) optimal* für Bagger von 26 bis 43 to

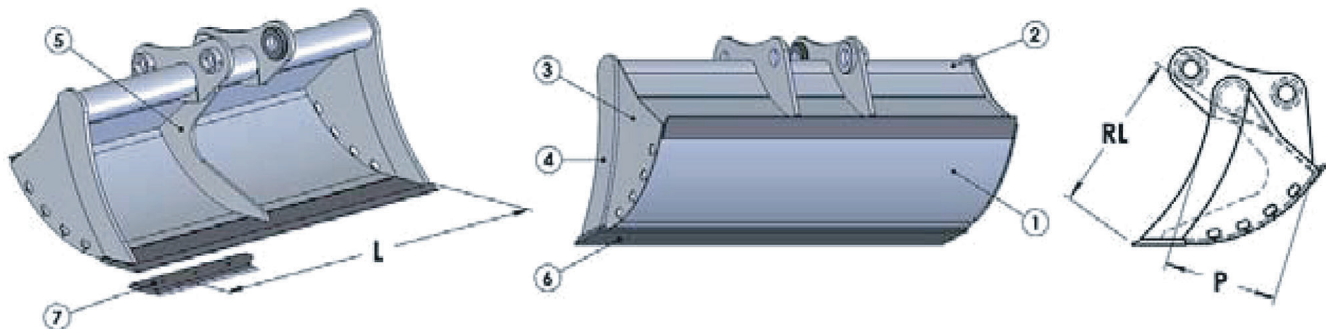
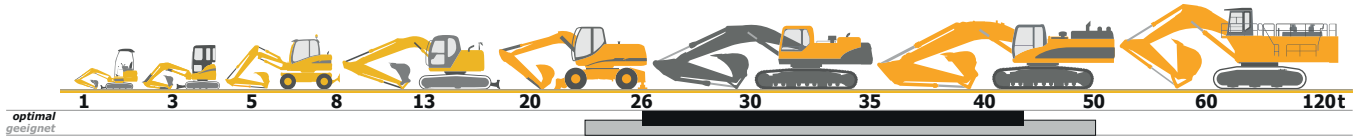

Klasse Class Classe	Bestell Nr. Code Code	L mm.	Cap. SAE Lt.	Gewicht kg Weight Poids	RL mm.	P mm.	Preis € Price List Tarif	Unterschraubmesser Bolt on Blade Lame boulonnées
T.68 T.69 T.70 26-43 ton	T68PFR180	1800	956	703	860	529		
	T68PFR200	2000	1074	756				
	T68PFR220	2200	1191	808				
	T68PFR240	2400	1309	861				
	T68PFR250	2500	1366	887				
		1	2	3	4	5	6	7 Optional
Material	Material Matériel	Fe 510	Fe 510	Fe 510	Fe 510	Fe 510	Hb 400	Hb 400
Stärke	Thickness Espessure	10 mm	177.8 x 20 mm	10 mm	30 mm	25 mm	300 x 30 mm	250 x 25 mm

*optimal = für Bagger von 26 bis 43 t mit Standard-Ausrüstung.

T.68 Akermann H 14B; Atlas 1804/1804M/180 4LC/1902; Benati 230CSB/270CSB/370/3.28/3.30; Benfra 12C/9.11/9.12; Case 1288CK/CX 290; Caterpillar 225D/229D/231/322B/322C/323/325B/C/D; Cosmoter BAT 25C; Daewoo Doosan DH 280/280 LCIII/V/290LCV/S 300LCV; Fiat Hitachi FH 270.3/ EX 285; Fiat Kobelco EX 285LC; Fiat-Allis FE 28; Ford 50; Furukawa 645LS; Hitachi ZX 28 0LC/ZX 280LCN; Hydromac H 150/H 180; Hyundai 280LC/290 LC-3/7; JCB JS 3 00/JS 330; Kobelco SK 300/909; Komatsu PC 270/PC 280/PC 290-7/PC 300; Laltesi 541; Liebherr A 932 LIT/A 934 LIT/R 924B LIT/R 924 LIT; MF 550; New Holland E 305EL/LC; O&K RH 9E/F/G/PMS/RH 9.5/RH 8.5; PMI 1300/1500/8.30/8.34/9.26/9.30/9.35; Poclair 125; ROCK 150; Samsung SE 280 LC.2; Volvo EC 280/EC 290B.

T.70 Akermann H 16C; Atlas 2004; Benati 335/450/310CSB; Benfra 9.32; Case 1488, 9033/CX 330/CX 350; Caterpillar 330B/C/D/E; Daewoo Doosan DH 320/S 330III/V/S 360LCIII/S 340LCV; Fiat Hitachi FH 300.2/FH 330.3/EX 355; Fiat Kobelco EX 355EL/LC/BEN; Furukawa 650E; Halla HE 360LCH; Hitachi ZX 350LC/ZX 350LCN; Hydromac H 200; Hyundai H 230/H 270/R 320LC-3/7/R 360LC-3/7; Kobelco SK 330LC/912; Komatsu PC 340-7/PC 360; Laltesi 350 HD/551HD; Liebherr A 944 HD LIT/R 934B LIT/R 942 LIT/R 944 LIT/R 944B LIT; New Holland E 335LC/NLC/E 3 85EL/LC/BEH; O&K RH 12.5/RH 14; PMI 14855; Poclair 170; ROCK 200; Samsung SE 350LC.2; Volvo EC 330B/EC 340/EC 360B.

geeignet = für Bagger von 22 bis 45 t je nach Ausrüstung. Andere Klassen/Größen bedingt geeignet. Bei Bedarf bitte anfragen!



T.55 T.60 GRABENRÄUM-LÖFFEL (flaches Profil)

optimal* für Bagger von 12,5 bis 19 to

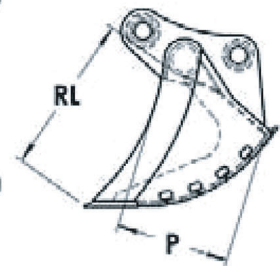
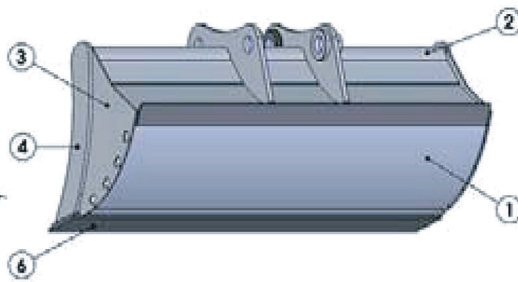
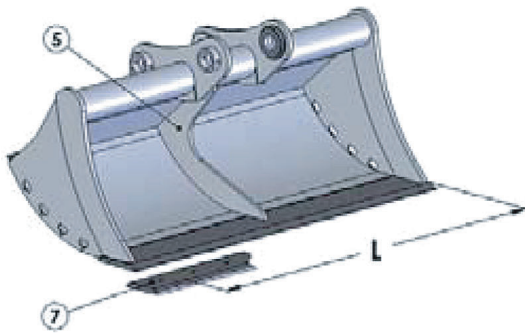
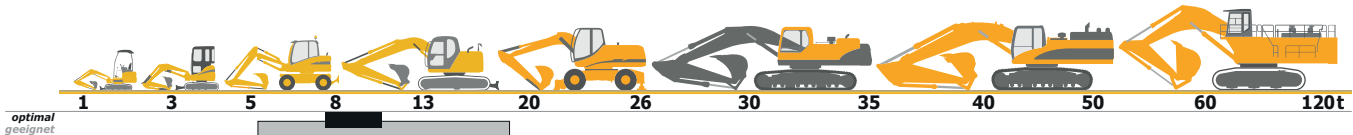

Klasse Class Classe	Bestell Nr. Code Code	L mm.	Cap. SAE Lt.	Gewicht kg Weight Poids	RL mm.	P mm.	Preis € Price List Tarif	Unterschraubmesser Bolt on Blade Lame boulonnées
T.55 T.60 12,5-19 ton	T55PFZ150	1500	353	305	570	345		
	T55PFZ180	1800	431	347				
	T55PFZ200	2000	483	374				
	T55PFZ220	2200	534	402				
		1	2	3	4	5	6	7 Optional
Material	Material <i>Matériel</i>	Fe 510	Fe 510	Fe 510	Fe 510	Fe 510	Hb 400	Hb 400
Stärke	Thickness <i>Espessure</i>	8 mm	127 x 14.2 mm	6 mm	20 mm	15 mm	200 x 25 mm	200 x 20 mm

*optimal = Standard-Bagger. Andere Klassen/Größen bedingt geeignet. Bei Bedarf bitte anfragen!

T.55 Akermann H 5; Atlas 1302/1304M/1304LC/1404M/14 04LC; Benati 90/120/140/145/3.15/3.16/3.17; Benfra 4R/4C/5/9.05/9.06; Case 588/9013/CX 130/CS 135SR/WX 125/WX 145; Caterpillar EB 120/205/206/M 312/M 313C/M 315/311C/312C/314C; Cosmoter BAT 12/14; Daewoo Doosan DH 130.2/S 110/S 130W-III/S 1 30LCV/S 140WV/S 160W V/S 140LCV/S 150LCV; Fai 1000 C/CH/GTH; Fiat Hitachi FH 120/FH 125W/FH 130.3/EX 135; Fiat Kobelco E 13 5/E 135SR/E 145W; Fiat-Allis E 12/FE 14/FE 16; Ford 42; Furukawa W 625E/W 630/W 635/W 725LS/W 730LS; Halla HE130W/H E 130LC; Hitachi ZX 130/ZX 135US/ZX 130W; Hydromac H 75; Hyundai 120W/R 130W-3/140W-7/R 130LC-3/R 140LC-7; JCB JS 130/JS 130W/JS 140/JS 145W; Kobelco SK 120/SK 135SRLC/90 3B; Komatsu PC 130/PW 130-7/PC 138US-2/PC 150.3; Lalesi 50/221/222; Liebherr R 310B/R 312/A 312 LIT/A 314/A 316/A 900; Mecalac 714MC/714MW; MF 330; New Holland E 145/E 135SRLC/SRL/MH CITY/MH 4.6; O&K RH 4/RH 4PLUS/RH 4PMS/RH CITY/MH 4/MH CITY/MHS/MH PLUS/RH 4.5/RH PLUS; PMI 700/8.15/8.17; Poclair TCS 45/60; ROCK 75; Samsung SE 130LC.2/SE 130W.3; Takeuch TB 1140; Volvo EC 130/EW 130/EC 140B/EW 140B/EC 150/EW 160 B.

T.60 Akermann H 7B/H 7C; Atlas 1604M/1604LC/1622; Benati 160/3.18; Benfra 6C/7R/7.07/7.08/9.07/9.08/9.20; Case 688/688B/788/CX 160/WX 150/WX 165/WX 170/CX 180; Caterpillar 211/212/213B/214/214B/315/317/318/M 316C/M 318C/315C; Cosmoter BAT 16; Daewoo Doosan DH 170/DH 180/S 170III/V/S 175LCV/S 180WV; FAI 1100; Fiat Hitachi FH 150.3/EX 165/ FH 150 W.2/FH 150W.3; Fiat Kobelco E 165 LC/E 175W; Fiat-Allis FE 18; Ford 44/45; Furukawa 635E; Hitachi ZX 160LC/ ZX 180LC/ZX 160W/ZX180W; Hydromac H 85; Hyundai R 160LC-3/7/R 170W-3/R 180LC-3/7; JCB JS 150/JS 160LC/JS 160W/ JS 175W/JS 180LC; Kobelco SK 150/SK 160LC/904/905B/SK 170LC; Komatsu PC 160-7/PW 160-7/PW 170/PC 180-7/PW 1 80-7; Lalesi 80/341/341HD; Liebherr A 9 00C/A 900B LIT/A 902 LIT/A 314 LIT/A 316 LIT/R 317; MF 350D/350E; New Holland E 175/MH PL US/MH PLUS C/MH 5.6; O&K RH 5/RH 5PLUS/RH 5 PMS/MH 5/MH 5PMS/RH 5.5; PMI 900/8.18; Poclair 61/75/688; ROCK 100; Samsung SE 170W.3; Volvo EC 160B/EC 170/EW 170/EC 180B/EW 180B.



Schwienbacher Abbruch Technik

Werkstatt • Lager • Service seit 1977

D-82229 Seefeld (bei München)

Graf-Toerring-Seefeld-Strasse 9b / 17

Tel. 08152 / 998 969-0 Fax.- 9

T.65 GRABENRÄUM-LÖFFEL (flaches Profil)

optimal* für Bagger von 19 bis 23 to

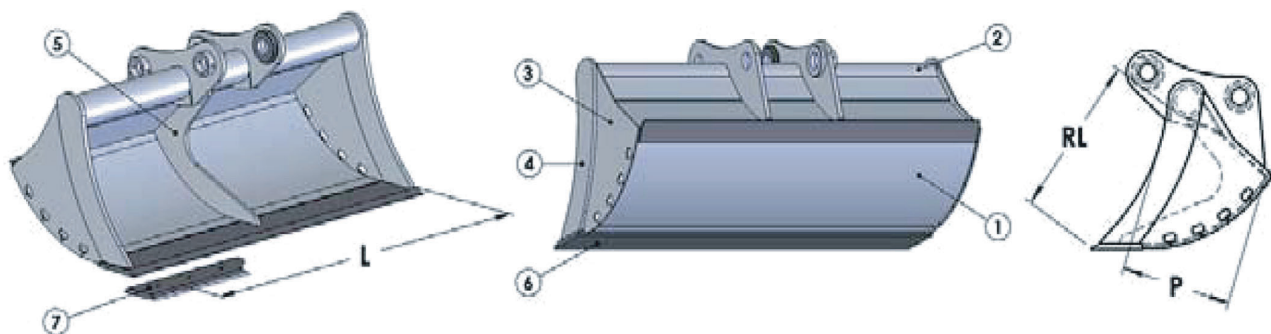
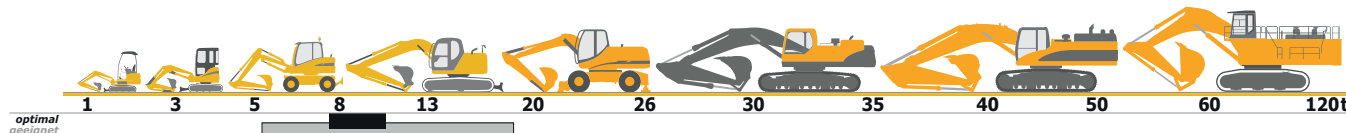

Klasse Class Classe	Bestell Nr. Code Code	L mm.	Cap. SAE Lt.	Gewicht kg Weight Poids	RL mm.	P mm.	Preis € Price List Tarif	Unterschraubmesser Bolt on Blade Lame boulonnées
T.65 23 ton	T65PFZ180	1800	546	448	648	460		
	T65PFZ200	2000	612	482				
	T65PFZ220	2200	677	517				
	T65PFZ240	2400	743	550				
	T65PFZ250	2500	775	567				
		1	2	3	4	5	6	7 Optional
Material	Material Matériel	Fe 510	Fe 510	Fe 510	Fe 510	Fe 510	Hb 400	Hb 400
Stärke	Thickness Espessure	8 mm	127 x 14.2 mm	8 mm	20 mm	20 mm	250 x 25 mm	200 x 20 mm

*optimal = **Standard-Bagger**. Andere **Klassen/Größen** bedingt geeignet. Bei Bedarf bitte anfragen!

Atlas 1702D/1704D/1704LC; **Benati** 190CSB/3.20/3.21; **Benfra** 8C/9.09; **Case** 888/888B/988/9021/CX 210/WX 185/WX 200/WX 210; **Caterpillar** 215C/219C/318B/319C/M 320/M 322C; **Cosmoter** BAT 18C; **Daewoo Doosan** S 200WIII/V/S 210WV/DH 220LC/S2 20LCVIII/V/S 225LCV; **FAI** 1200/1300CH/GTH/1400/1500; **Fiat Hitachi** FH 200W.3/EX 200/EX 215; **Fiat Kobelco** E 200SR/E 215 E; **Fiat-Allis** FE 20; **Ford** 47; **Furukawa** 640E/W 735LS/W 738LS; **Hitachi** ZX 210/ZX 210LC/ZX 21 0N/ZX 210W/ZX 225USR/ZX 225USRLC/ZX 225US/ZX 225USLC; **Hydromac** H 95/H 105/H 115; **Hyundai** R 200W/R 200LC/R 210LC-3/7; **JCB** JS 200W/JS 200 LC/JS 210/JS 220; **Kobelco** SK 200/SK 210LC/907/SK 200SR; **Komatsu** PC 200/PC 210/PC 228US-3/P W 200-7/PW 210/PW 220-7; **Laltesi** 441HD; **Liebherr** A 904C/A 904 LIT/A 912 LIT/A 914B/A 914 LIT/R 900B/C LIT/R 904 L IT; **MF** 450D/450E; **New Holland** E 215/E/LC/E 195EL/LC/E 200SR/SRLC/MH 6.6/MH 8.6; **O&K** RH 6B/C/D/E/F/MH 6B/C/D/E/F/RH 6 COMPAC; **PMI** 822/9.21/9.22; **Poclair** 81/888; **ROCK** 130/135; **Samsung** SE 210LC.3/SE 210W.2; **Terex** TC 210 LC/TC 210NLC/TC 225LC/TC 225NLC; **Volvo** EC 200/EW 200/EC 210B.

Info: Stand 09/2020



Schwiebacher Abbruch Technik

Werkstatt • Lager • Service seit 1977

D-82229 Seefeld (bei München)

Graf-Toerring-Seefeld-Strasse 9b / 17

Tel. 08152 / 998 969-0 Fax.- 9

T.66 GRABENRÄUM-LÖFFEL (flaches Profil) optimal* für Bagger von 23 bis 263 to

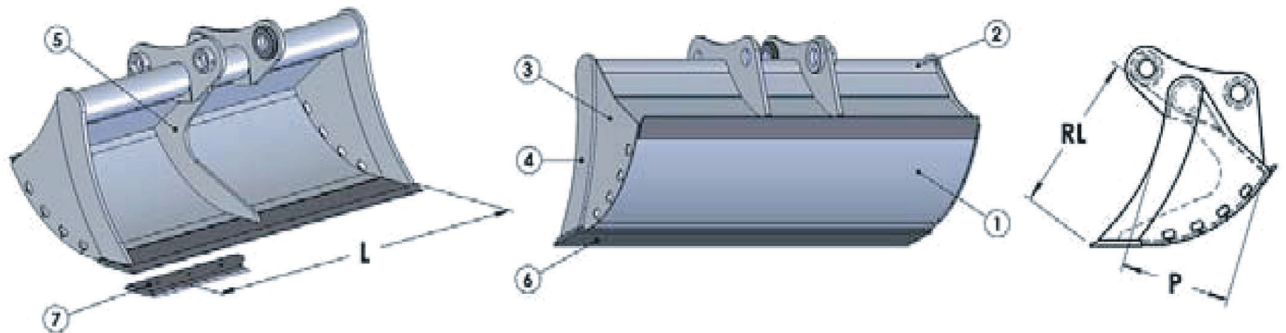
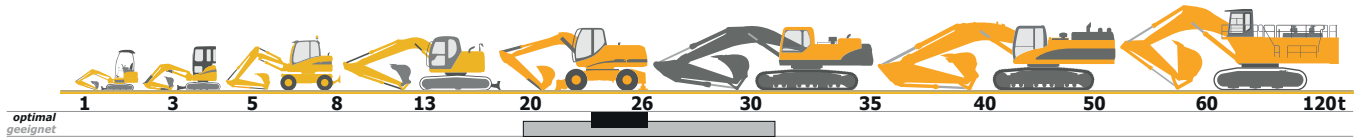

Klasse Class Classe	Bestell Nr. Code Code	L mm.	Cap. SAE Lt.	Gewicht kg Weight Poids	RL mm.	P mm.	Preis € Price List Tarif	Unterschraubmesser Bolt on Blade Lame boulonnées
T.66 23-26 ton	T66PFZ180	1800	738	489	750	460		
	T66PFZ200	2000	828	526				
	T66PFZ220	2200	917	562				
	T66PFZ240	2400	1007	598				
	T66PFZ250	2500	1052	617				
		1	2	3	4	5	6	7 Optional
Material	Material <i>Matériel</i>	Fe 510	Fe 510	Fe 510	Fe 510	Fe 510	Hb 400	Hb 400
Stärke	Thickness <i>Espessore</i>	8 mm	152.4 x 16 mm	8 mm	25 mm	20 mm	250 x 25 mm	200 x 20 mm

*optimal = **Standard-Bagger**. Andere **Klassen/Größen** bedingt geeignet. Bei Bedarf bitte anfragen!

Akermann H 10B; **Atlas** 1802; **Benati** 3.22/3.22B; **Benfra** 10C/9.10/9.24;
Case 1088/1188/CX 225/CX 255 SR/CX 230/CX 240/WX 240; **Caterpillar** 215D/219D/320B/C/M 325C/321C;
Daewoo Doosan S 240/S 250/S 255LCV; **FAI** 1600; **Fiat Hitachi** FH 220.3/FH 240.3/EX 235/EX 255;
Fiat Kobelco EX 255EL/LC/E 235E/E 235SR; **Fiat-Allis** FE 24; **Ford** 48; **Furukawa** 740LS/640E;
Halla HE 220LC; **Hitachi** ZX 240/ZX 250/ZX 250LC/ZX 250LCN; **Hydromac** H 135/H 145;
Hyundai 228LC/R 250LC-3/7; **JCB** JS 235/JS 240/JS 260; **Kobelco** SK 220/SK 235 R/SK 250LC;
Komatsu PC 220/PC 230N-7/PC 240-7; **Laltes** 420/500HD; **Liebherr** A 924B/A 924 LIT/R 912 LIT/R 9 14 LIT/R 914B LIT;
New Holland E 245/E 265EL/LC/E 235SRNLC/SRLC; **O&K** RH 6PMS/RH 6.20/RH 6.22/RH 8PMS/MH 8.6/RH 6.5;
PMI 1000/1200/8.25/9.25; **Poclair** 90/115; **Samsung** SE 240LC.3;
Terex TC 240 LC/TC 240NLC/TC 260LC/TC 260NLC; **Volvo** EC 230/EW 230/EC 240B.



Schwiebacher Abbruch Technik

Werkstatt • Lager • Service seit 1977

D-82229 Seefeld (bei München)

Graf-Toerring-Seefeld-Strasse 9b / 17

Tel. 08152 / 998 969-0 Fax.- 9

T.68/T.69/T.70 GRABENRÄUM-LÖFFEL (flaches Profil) optimal* für Bagger von 26 bis 43 to

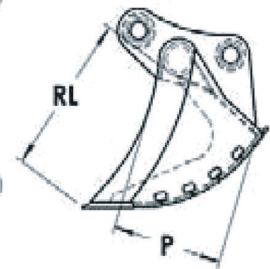
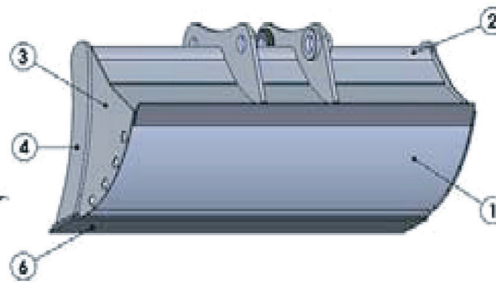
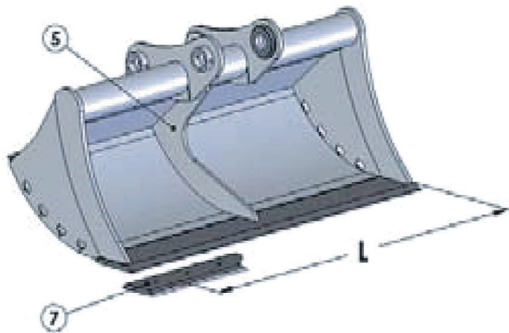
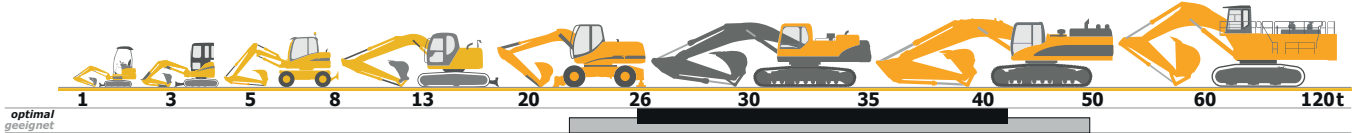

Klasse Class Classe	Bestell Nr. Code Code	L mm.	Cap. SAE Lt.	Gewicht kg Weight Poids	RL mm.	P mm.	Preis € Price List Tarif	Unterschraubmesser Bolt on Blade Lame boulonnées
T.68 T.69 T.70 26-43 ton	T68PFZ180	1800	956	703	860	529		
	T68PFZ200	2000	1074	756				
	T68PFZ220	2200	1191	808				
	T68PFZ240	2400	1309	861				
	T68PFZ250	2500	1366	887				
		1	2	3	4	5	6	7 Optional
Material	<i>Material</i> <i>Matériel</i>	Fe 510	Fe 510	Fe 510	Fe 510	Fe 510	Hb 400	Hb 400
Stärke	<i>Thickness</i> <i>Espessure</i>	10 mm	177.8 x 20 mm	10 mm	30 mm	25 mm	300 x 30 mm	250 x 25 mm

*optimal = **Standard-Bagger**. Andere **Klassen/Größen** bedingt geeignet. Bei Bedarf bitte anfragen!

T.68 Akermann H 14B; Atlas 1804/1804M/180 4LC/1902; Benati 230CSB/270CSB/370/3.28/3.30; Benfra 12C/9.11/9.12; Case 1288CK/CX 290; Caterpillar 225D/229D/231/322B/322C/323/325B/C/D; Cosmoter BAT 25C; Daewoo Doosan DH 280/280 LCIII/V/290LCV/S 300LCV; Fiat Hitachi FH 270.3/ EX 285; Fiat Kobelco EX 285LC; Fiat-Allis FE 28; Ford 50; Furukawa 645LS; Hitachi ZX 28 0LC/ZX 280LCN; Hydromac H 150/H 180; Hyundai 280LC/290 LC-3/7; JCB JS 3 00/JS 330; Kobelco SK 300/909; Komatsu PC 270/PC 280/PC 290-7/PC 300; Laltesi 541; Liebherr A 932 LIT/A 934 LIT/R 924B LIT/R 924 LIT; MF 550; New Holland E 305EL/LC; O&K RH 9E/F/G/PMS/RH 9.5/RH 8.5; PMI 1300/1500/8.30/8.34/9.26/9.30/9.35; Poclain 125; ROCK 150; Samsung SE 280 LC.2; Volvo EC 280/EC 290B.

T.70 Akermann H 16C; Atlas 2004; Benati 335/450/310CSB; Benfra 9.32; Case 1488, 9033/CX 330/CX 350; Caterpillar 330B/C/D/E; Daewoo Doosan DH 320/S 330III/V/S 360LCIII/S 340LCV; Fiat Hitachi FH 300.2/FH 330.3/EX 355; Fiat Kobelco EX 355EL/LC/BEN; Furukawa 650E; Halla HE 360LCH; Hitachi ZX 350LC/ZX 350LCN; Hydromac H 200; Hyundai H 230/H 270/R 320LC-3/7/R 360LC-3/7; Kobelco SK 330LC/912; Komatsu PC 340-7/PC 360; Laltesi 350 HD/551HD; Liebherr A 944 HD LIT/R 934B LIT/R 942 LIT/R 944 LIT/R 944B LIT; New Holland E 335LC/NLC/E 3 85EL/LC/BEH; O&K RH 12.5/RH 14; PMI 14855; Poclain 170; ROCK 200; Samsung SE 350LC.2; Volvo EC 330B/EC 340/EC 360B.